

|                     |                               |             |                    |
|---------------------|-------------------------------|-------------|--------------------|
| Product Series Code | <b>GRB</b>                    | Brand       | <b>GOTREND</b>     |
| File Version        | <b>GRB0520P-09A09YDP-V1R0</b> | Editor      | <b>Terry</b>       |
| Established Date    | <b>2016.11.16</b>             | Description | <b>Dip R Choke</b> |
| Latest Edit Date    | <b>2016.11.16</b>             | Pages       | <b>Page : 2</b>    |

### Features & Application:

- \* Drum Choke with low cost and high reliability.
- \* Fit for power line & signal line circuit
- \* To help you go pass the CE/FCC standard.
- \* Mobile Device / Handheld Device / LowProfile Device / Panel...

### Part No Example:

GRB 0520 P - 09 A 09 Y DP  
 1 2 3 4 5 6 7 8

- 1.GOTREND Series : GRB
- 2.Core Dimension Code : Width x Length
- 3.P = Pb free < 1000ppm
- 4.Wire Size : 09=0.9mm ..... etc.
- 5.Wire Count : A=Single , B=2 Wire , C=3 Wire ..... etc.
- 6.Wire Turns : 09=09 Turns
- 7.Wire Color : Y=Copper Yellow , R=Copper Red
- 8.Pin Foot : DP=Dip

### Custom Design @ 1KHz , 0.25V

| P/N               | Inductance(uH) | DCR (m ohm) | IDC (A)  |
|-------------------|----------------|-------------|----------|
| GRB0520P-09A09YDP | 2.5 uH +/- 20% | 40.0 Max.   | 5.0 Max. |

### Test Equipment :

- \* HP4284A,HP42841A- L,IDC,Q.RDC
- \* HP8753D NETWORK ANALYZER- SRF

Standard Atmospheric Conditions:

Ambient Temp:20+/-15°C

Relative Humidity:65+/-20%

If there may be any doubt on the result, measurement shall be made within the following limits:

Ambient Temp:25+/-5°C

Relative Humidity:75+/-10%

### Operating & Storage Condition:

OPERATING TEMP:-20~+85°C

STORAGE TEMP:-20~+85°C

STORAGE LIFE TIME: 12 MONTH @25°C , RH 65%

### Attention & Caution:

Please avoid following matters:

- \* Splashing water or salt water
- \* Toxic Gas (Hydrogen sulfide, Sulfurous acid, Chlorine, Ammonia)
- \* Vibrations or shocks which exceed the specified condition
- \* Dew condenses
- \* Please be careful for the stress to this product by board flexure or something after the mounting.

### Product Structure

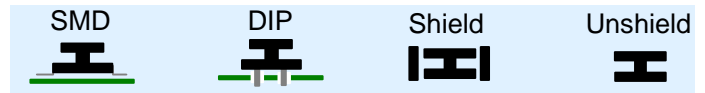

### 2005 RoHS Compliant - SGS Certified Result

| 鉛<br>Pb  | 鎘<br>Cd | 汞<br>Hg | 六價鉻<br>Cr+6 | 溴化聯苯<br>PBB | 溴化聯苯<br>醚PBDE |
|----------|---------|---------|-------------|-------------|---------------|
| <1000ppm | ND      | ND      | ND          | ND          | ND            |

### DIMENSION : [ mm ]

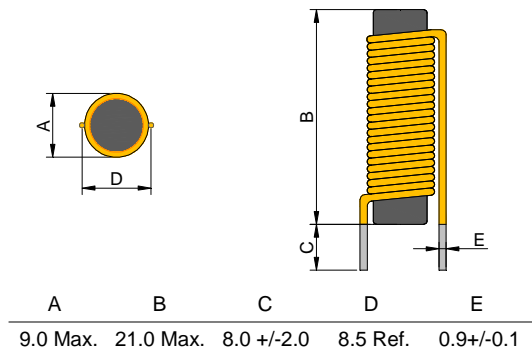

### SCHEMATIC:

