



Product Series Code	<b>GRB</b>	Brand	GOTREND
File Version	GRB0525P-18A11YDP-V1R0	Editor	Teddy
Established Date	2011.11.25	Description	Dip R Choke
Latest Edit Date	2011.11.25	Pages	Page : 2

### Features & Application:

- \* Drum Choke with low cost and high reliability.
- \* Fit for power line & signal line circuit
- \* To help you go pass the CE/FCC standard.
- \* Mobile Device / Handheld Device / LowProfile Device / Panel...

### Part No Example:

GRB 0525 P - 18 A 11 Y DP  
 1 2 3 4 5 6 7 8

- 1.GOTREND Series : GRB
- 2.Core Dimension Code : Width x Length
- 3.P = Pb free < 1000ppm
- 4.Wire Size : 18 = 1.8 mm ..... etc.
- 5.Wire Count : A = Single , B = 2 Wire , C = 3 Wire ..... etc.
- 6.Wire Turns : 11 = 11.5 Turns
- 7.Wire Color : Y = Copper Yellow , R = Copper Red
- 8.Pin Foot : DP = Dip

### Custom Design @ 1KHz , 0.25V

P / N	Inductance (uH)	DCR (m Ohm)
GRB0525P-18A11YDP	1.3 min.	8.0 max.

### Test Equipment :

- \* HP4284A,HP42841A- L,IDC,Q.RDC
- \* HP8753D NETWORK ANALYZER- SRF

Standard Atmospheric Conditions:

Ambient Temp:20+/-15°C

Relative Humidity:65+/-20%

If there may be any doubt on the result, measurement shall be made within the following limits:

Ambient Temp:25+/-5°C

Relative Humidity:75+/-10%

### Operating & Storage Condition:

OPERATING TEMP:-20~+85°C

STORAGE TEMP:-20~+85°C

STORAGE LIFE TIME: 12 MONTH @25°C , RH 65%

### Attention & Caution:

Please avoid following matters:

- \* Splashing water or salt water
- \* Toxic Gas (Hydrogen sulfide, Sulfurous acid, Chlorine, Ammonia)
- \* Vibrations or shocks which exceed the specified condition
- \* Dew condenses
- \* Please be careful for the stress to this product by board flexure or something after the mounting.

### Product Structure

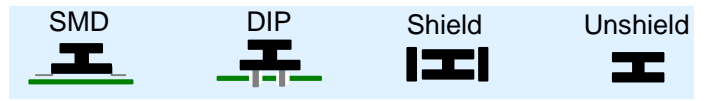

### 2005 RoHS Compliant - SGS Certified Result

鉛 Pb	鎘 Cd	汞 Hg	六價鉻 Cr+6	溴化聯苯 PBB	溴化聯苯 醚PBDE
<1000ppm	ND	ND	ND	ND	ND

### DIMENSION : [ mm ]

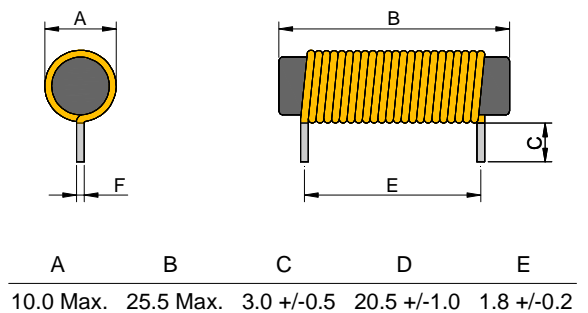

### SCHEMATIC:

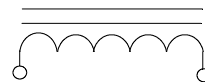

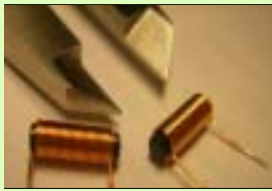

Product Series Code	<b>GRB</b>	Brand	<b>GOTREND</b>
File Version	<b>GRB0525P-18A11YDP-V1R0</b>	Editor	<b>Teddy</b>
Established Date	<b>2011.11.25</b>	Description	<b>Dip R Choke</b>
Latest Edit Date	<b>2011.11.25</b>	Pages	<b>Page : 3</b>

NO	ITEM	TEST CONDITIONS	Sample Qty/pcs	Spec	Result																
1	Dimension 本體相關呎吋	Actual Size ...	10	Meet Spec	ok																
2	Thermal Shock (Temperature Cycle) 溫度循環試驗	Temperature:-20 ° C/ +85 ° C kept stabilized for 30 minutes each Cycle: 100 Cycles(power off)	10	Elec. no variation Appearance no deformation	ok																
3	Humidity Resistance 耐濕試驗	Humidity: 90%~ 95% RH Temperature: 40± 2 ° C Test Time: 120± 2 Hours	10	Elec. no variation Appearance no deformation	ok																
4	HighTemperature 耐熱試驗	Temperature: 85± 2 ° C Humidity: 20% Testing Time: 120± 2 Hours	10	Elec. no variation Appearance no deformation	ok																
5	Low Temperature 耐寒試驗	Temperature: -20 ± 2 ° C Time: 120± 2 Hours	10	Elec. no variation Appearance	ok																
6	Temperature and Humidity Cycle 溫/濕度循環試驗	<table border="1"> <thead> <tr> <th>Step</th> <th>Temp</th> <th>Humidity</th> <th>Time</th> </tr> </thead> <tbody> <tr> <td>1</td> <td>25± 2 ° C</td> <td>95~100%RH</td> <td>3.0Hr</td> </tr> <tr> <td>2</td> <td>55± 2 ° C</td> <td>95~96%RH</td> <td>9.5Hr</td> </tr> <tr> <td>3</td> <td>25± 2 ° C</td> <td>95~100%RH</td> <td>9.5Hr</td> </tr> </tbody> </table>	Step	Temp	Humidity	Time	1	25± 2 ° C	95~100%RH	3.0Hr	2	55± 2 ° C	95~96%RH	9.5Hr	3	25± 2 ° C	95~100%RH	9.5Hr	10	Elec. no variation Appearance no deformation	ok
Step	Temp	Humidity	Time																		
1	25± 2 ° C	95~100%RH	3.0Hr																		
2	55± 2 ° C	95~96%RH	9.5Hr																		
3	25± 2 ° C	95~100%RH	9.5Hr																		
7	Vibration 振動性試驗	Frequency: 10Hz~55Hz Amplitude: 1.5mm Direction: X,Y,Z Time: 2 Hours each	10	Elec. no variation Appearance no deformation	ok																
8	Soldering Heat Resistance 耐熱 焊性試驗	Preheat:120 ~ 150 ° C (6 sec) Solder:H63A(eutectic solder) Solder Temp.: 260 ± 5 ° C Flux: Rosin Dip time: 10± 1 seconds	10	Elec. no variation Appearance no deformation	ok																
9	High-Voltage 高壓電擊試驗	100 V DC between core & winding	10	Elec. no variation Appearance no deformation	ok																
10	ORT:on going reliability test 負載電氣試驗	Elec loading & spec test... base on Spec for approval	10	Elec. no variation Appearance no deformation	ok																

BOX Package: cm

