



Product Series Code	GW	Brand	GOTREND
File Version	GW483209PR-032B15YTS-V1R0	Editor	Teddy
Established Date	2013.03.29	Description	Wireless Charging Receiving Coil
Latest Edit Date	2013.03.29	Pages	Page : 2

Features & Application :

- * Wireless charging receiving coil
- * High permeability shielding for wireless charging receiving coils
- * Blocks charging flux from sensitive components or batteries
- * High saturation powered iron - not affected by permanent locating magnets
- * Durable construction
- * Compliant to RoHS Directive 2002 / 95 / CE

Part No Example:

GW 483209 P R - 032 B 15 Y TS

1 2 3 4 5 6 7 8 9

1. Product Code : GW
2. Size Code : 483209 = 48 X 32 X 0.94
3. P = Pb Free < 1000ppm
4. [R] : Rx
5. Wire Size : 0.32 = 0.32 mm etc.
6. Wire Count : A = Single , B = 2 Wire , C = 3 Wire etc.
7. Wire Turns (Ts) : 15 = 15.0 Ts
8. Wire Color : Y = Copper Yellow , R = Copper Red
9. [TS] : Material Code

Test Equipment :

* HP4284A , HP42841A - L , IDC , Q , RDC

Standard Atmospheric Conditions :

Ambient Temp:20+/-15°C

Relative Humidity:65+/-20%

If there may be any doubt on the result, measurement shall be made within the following limits:

Ambient Temp:25+/-5°C

Relative Humidity:75+/-10%

Operating & Storage Condition :

OPERATING TEMP : -25 ~ +85°C

STORAGE TEMP : -40 ~ +85°C

STORAGE LIFE TIME : 12 MONTH @25°C , RH 40~65%

Product Structure

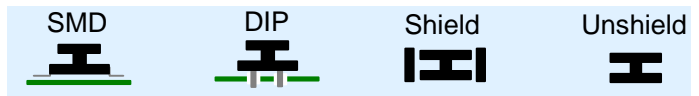

2005 RoHS Compliant - SGS Certified Result

鉛 Pb	鎘 Cd	汞 Hg	六價鉻 Cr+6	溴化聯苯 PBB	溴化聯苯 醚PBDE
<1000ppm	ND	ND	ND	ND	ND

DIMENSION : [mm]

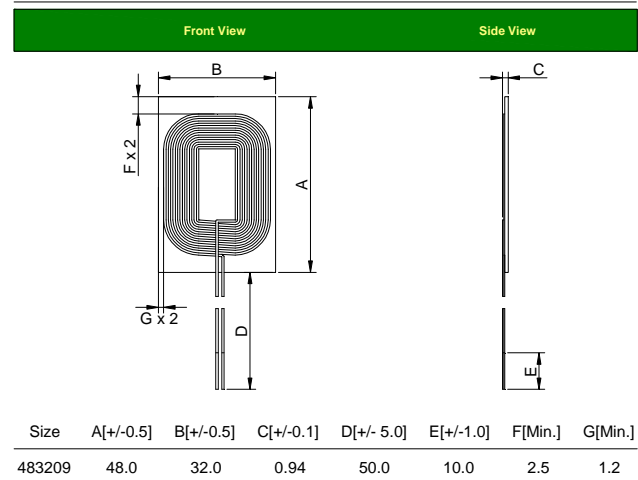

Attention & Caution :

Please avoid following matters:

- * Splashing water or salt water
- * Toxic Gas (Hydrogen sulfide, Sulfurous acid, Chlorine, Ammonia)
- * Vibrations or shocks which exceed the specified condition
- * Dew condenses
- * Please be careful for the stress to this product by board flexure or something after the mounting.

Electrical Characteristics :

GOTREND PN	Inductance (uH)	DCR (m Ohm)
GW483209PR-032B15YTS	11.8 +/- 8%	210.0 Typ. / 250.0 Max.

* Inductance Test Condition@100KHz,1.0Vrms, 25°C Ambient

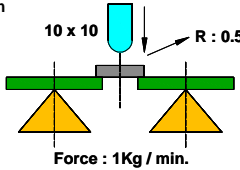
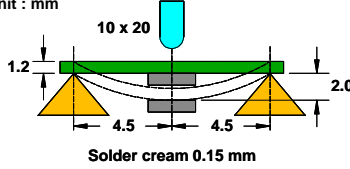

Product Series Code	GW	Brand	GOTREND
File Version	GW483209PR-032B15YTS-V1R0	Editor	Teddy
Established Date	2013.03.29	Description	Wireless Charging Receiving Coil
Latest Edit Date	2013.03.29	Pages	Page : 3

NO	ITEM	TEST CONDITIONS	Sample Qty/pcs	Specification	Result																
1	Dimension 本體相關尺寸	Actual Size ...	10	Meet Spec	ok																
2	Thermal Shock (Temperature Cycle) 溫度循環試驗	Temperature : -40 ° C~+85 ° C kept stabilized for 30 minutes each Cycle : 100 Cycle (Power off)	10	Elec. no variation Appearance no deformation	ok																
3	Humidity Resistance 耐濕試驗	Humidity: 90%~ 95% RH Temperature: 40± 2 ° C Test Time: 96± 2 Hours	10	Elec. no variation Appearance no deformation	ok																
4	High Temperature 耐熱試驗	Temperature: 85± 2 ° C Testing Time: 96± 2 Hours	10	Elec. no variation Appearance no deformation	ok																
5	Low Temperature 耐寒試驗	Temperature: -40 ± 2 ° C Time: 96± 2 Hours	10	Elec. no variation Appearance	ok																
6	Temperature and Humidity Cycle 溫/濕度循環試驗	<table border="1"> <thead> <tr> <th>Step</th> <th>Temp</th> <th>Humidity</th> <th>Time</th> </tr> </thead> <tbody> <tr> <td>1</td> <td>25± 2 ° C</td> <td>90~95%RH</td> <td>3.0Hr</td> </tr> <tr> <td>2</td> <td>55± 2 ° C</td> <td>95~96%RH</td> <td>5.0Hr</td> </tr> <tr> <td>3</td> <td>25± 2 ° C</td> <td>90~95%RH</td> <td>3.0Hr</td> </tr> </tbody> </table> Cycle: 20 Cycles	Step	Temp	Humidity	Time	1	25± 2 ° C	90~95%RH	3.0Hr	2	55± 2 ° C	95~96%RH	5.0Hr	3	25± 2 ° C	90~95%RH	3.0Hr	10	Elec. no variation Appearance no deformation	ok
Step	Temp	Humidity	Time																		
1	25± 2 ° C	90~95%RH	3.0Hr																		
2	55± 2 ° C	95~96%RH	5.0Hr																		
3	25± 2 ° C	90~95%RH	3.0Hr																		
7	Vibration 振動性試驗	Frequency: 10Hz~50Hz Amplitude: 1.5mm Direction: X,Y,Z Time: 2 Hours each	10	Elec. no variation Appearance no deformation	ok																
8	Solderability 吃錫性試驗	Solder : Sn96.5 / Ag3.0 / Cu0.5 Pre-Heating : 150± 10 ° C / 1min. to 2min. Solder Temperature: 245± 5 ° C Immersion Time 4s ± 1s Electrode shall be at least 75%	10	Elec. no variation Appearance no deformation	ok																
9	Iron Solder Heat Resistance 手焊耐熱試驗	Solder Temp. 350 ± 5 ° C Flux : Rosin Time : 3± 1 seconds	10	Elec. no variation Appearance no deformation	ok																
10	Bending Strength 折斷力試驗	Unit : mm  Force : 1Kg / min.	10	Elec. no variation Appearance no deformation	ok																
11	Flexure Strength 彎曲試驗	Unit : mm  Solder cream 0.15 mm	10	Elec. no variation Appearance no deformation	ok																
12	High-Voltage 高壓電擊試驗	100 V DC Between core & winding	10	Elec. no variation Appearance no deformation	ok																



Product Series Code	GW	Brand	GOTREND
File Version	GW483209PR-032B15YTS-V1R0	Editor	Teddy
Established Date	2013.03.29	Description	Wireless Charging Receiving Coil
Latest Edit Date	2013.03.29	Pages	Page : 4

Package Information:

BOX Package: cm

Small Box:500 pcs
Large Box:3000 pcs

